

# Chemistry vacuum system MD 4C NT +2AK

[Link to the website](#)



## Product description

This chemistry vacuum system has a wide range of applications like evacuation, evaporation and pumping of gases and vapors in chemical, biological and pharmaceutical laboratories that do not require condensation of solvent vapors at the outlet. This system is well proven for high vacuum requirements with high boiling solvents. Typical applications are vacuum concentrators, rotary evaporators and drying ovens. The separator at the inlet (AK), made of glass with a protective coating, retains particles and liquid droplets. The catchpot at the outlet collects condensate, avoids condensate backflow towards the pump and reinforces the whisper-quiet operation of the pump.

## Performance features

- outstanding chemical resistance and superior vapor tolerance
- exceptionally high performance even at low vacuum
- excellent ultimate vacuum even with gas ballast
- whisper quiet and very low vibration
- separators at inlet and outlet to collect condensates

## Ordering data

Product name	Nominal mains voltage   mains frequency	Plug type	Articleno.
MD 4C NT +2AK	230 V   50-60 Hz	CEE	20736600
MD 4C NT +2AK	100-115 V   50-60 Hz 120 V   60 Hz	US	20736603

## Items supplied

Pumping unit completely mounted, ready for use, with manual.

## Accessories

- Silencer with hose 5cm DN 8-10mm (20636588)
- Adjustable elbow DN 10/8 mm (20637873)
- Vacuum tubing transparent DN 8 mm (20686061)
- Set of diaphragms and valves MD 4C NT/VARIO / PC 3003 / PC 3004 (20696870)
- Silencer with hose 5cm DN 8-10mm (20636588)
- Vacuum tubing transparent DN 8 mm (20686061)
- Set of diaphragms and valves MD 4C NT/VARIO / PC 3003 / PC 3004 (20696870)

## Technical data

Max. pumping speed 50 Hz (m <sup>3</sup> /h)	3.4 m <sup>3</sup> /h
Max. pumping speed 60 Hz (cfm)	2.2 cfm
Ultimate vacuum	1.5 mbar / 1.1 torr
Ultimate vacuum with gas ballast	3 mbar / 2.2 torr
Number of heads	4
Number of stages	3
Permissible ambient temperature range (operation)	10 - 40 °C
Permissible ambient temperature range (storage)	-10 - 60 °C
Max. outlet pressure (abs.)	1.1 bar
Inlet connection	Hose nozzle DN 8-10 mm
Outlet connection	Hose nozzle DN 8-10 mm
Rated motor power	0.25 kW
Rated speed 50/60 Hz	1500/1800 min <sup>-1</sup>
Protection class IEC 60529	IP 40
Dimensions (L x W x H)	319 mm x 243 mm x 374 mm
Weight	16.7 kg
Noise (sound pressure level) in dBA at 50 Hz or 1500 rpm/62% (VARIO)/1500 rpm (VARIO-SP)/12500 Upm (VACUU·PURE®)	45 dBA
NRTL certification	Yes

Pumping speed graph at 50 Hz

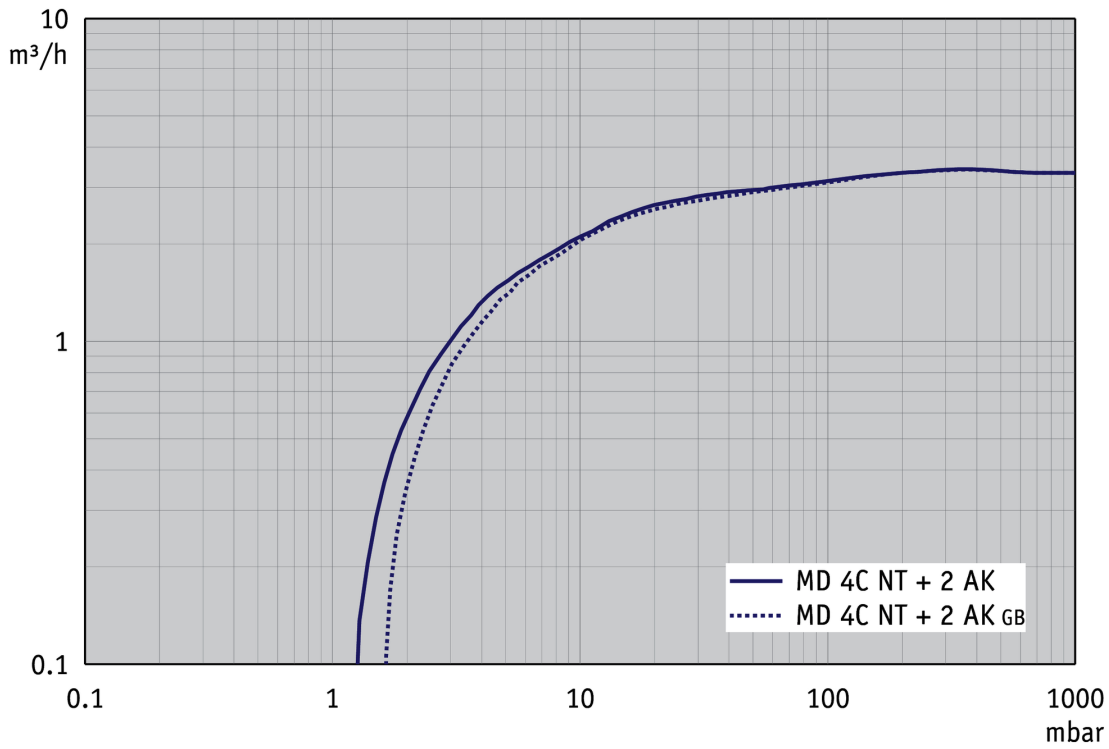

Pump down graph at 50 Hz (10 l volume)

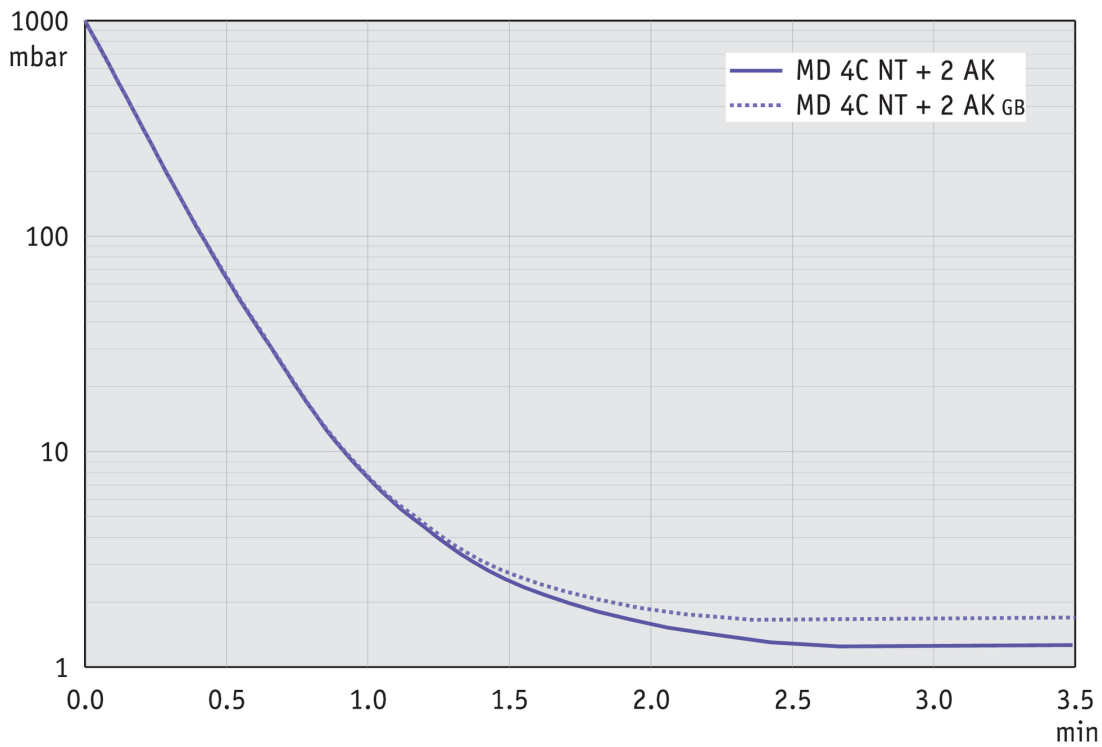

Pumping speed graph at 60 Hz

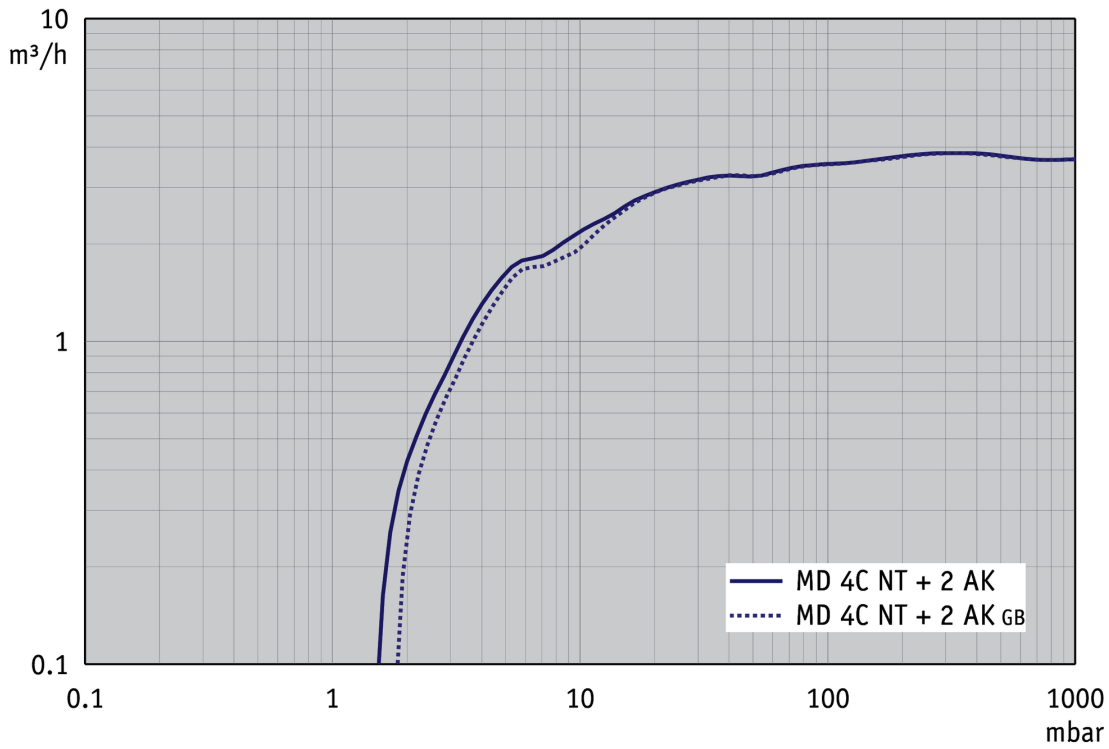

Pump down graph at 60 Hz (10 l volume)

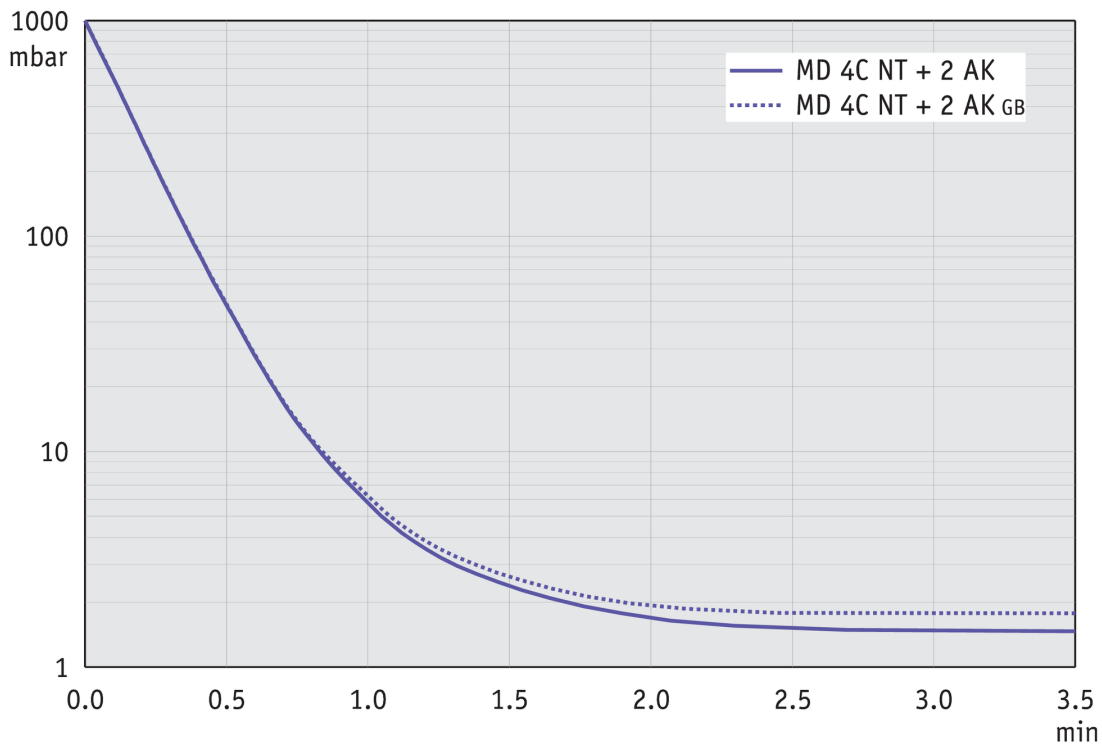

## Dimension sheet

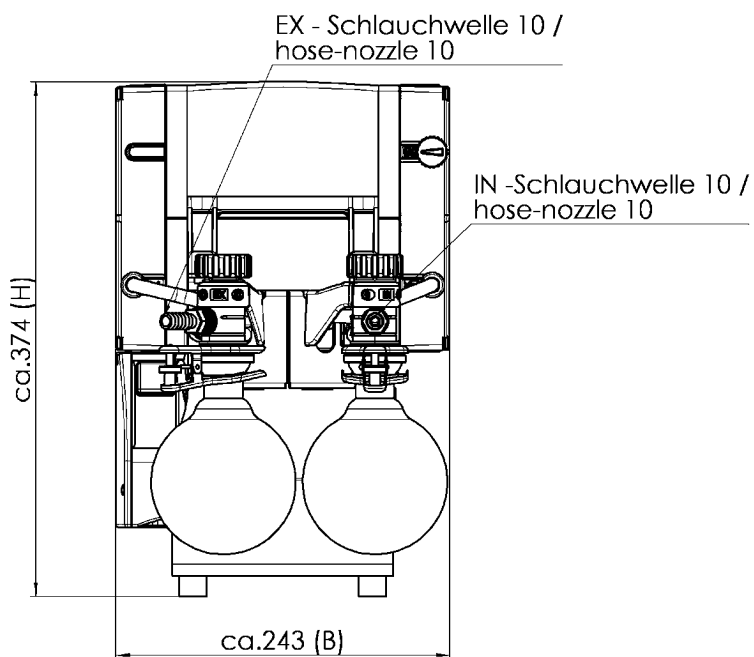

Alle Maße / all dimensions (mm)

Gewicht / weight: 16,7 kg

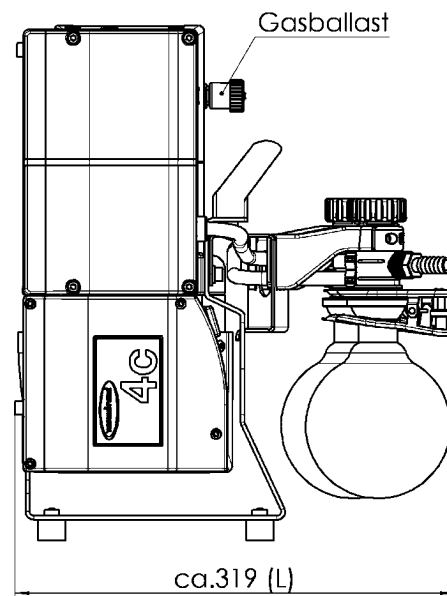

VACUUBRAND MD 4C NT 2AK  
Version 2009/03/16

VACUUBRAND GMBH + CO KG  
P.O. Box 1664  
97877 Wertheim  
T +49 9342 808 5550  
F +49 9342 808 5555

info@vacuubrand.com  
www.vacuubrand.com

**VACUUBRAND®**

VACUUBRAND is part of the Brand group, a manufacturer of high-quality and innovative laboratory equipment and vacuum technology with a global team of approx. 1,000 employees.

With highly motivated and qualified employees, we manufacture the world's most comprehensive product family for vacuum generation, measurement and control for the rough and fine vacuum range in the laboratory.

**All with one goal:**

Enabling our customers to run reliable, safe and efficient processes. This is why we commit ourselves to continuous innovation, first-class performance, and outstanding quality.

Engineering excellence is central to our ability to deliver products and solutions renowned for their quality, durability, and reliability. Innovative technology, high quality materials and extensive testing deliver unmatched performance - engineered and manufactured in Germany.

Together with you, our experts will find the best solution for your application and provide you with first-class service along the way.

BRAND (Shanghai) Trading Co., Ltd.  
Shanghai, China

T +86 21 6422 2318  
info@brand.com.cn  
china.brand.com.cn

BRAND Scientific Equipment Pvt. Ltd.  
Mumbai, India

T +91 22 42957790  
customersupport@brand.co.in  
www.brand.co.in

BRANDTECH® Scientific, Inc.  
Essex, CT. United States of America

T +1 860 767 2562  
info@brandtech.com  
www.brandtech.com